

Meyn feather press

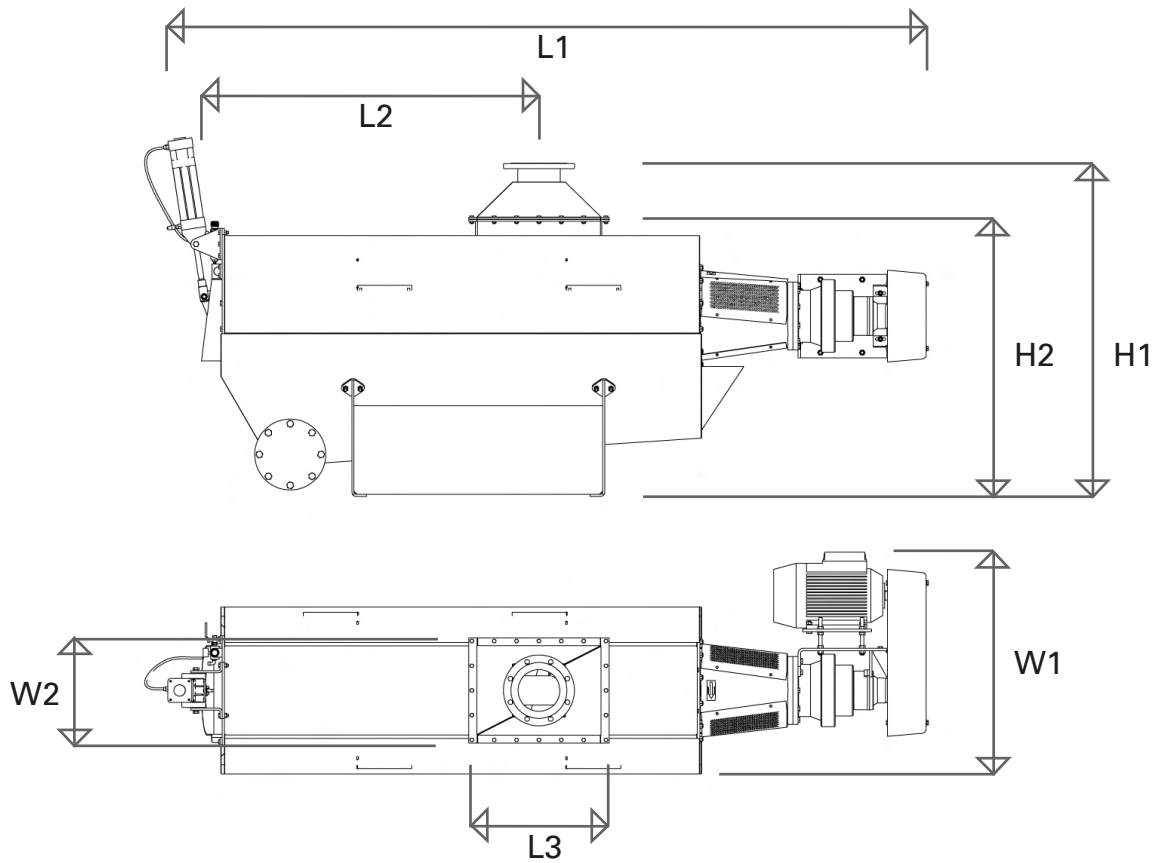

Technical Data Sheet

| | | |
|---------------------------------|--------------------|--------|
| Capacity | BPH | 12,000 |
| Transport water up to | m ³ /hr | 60 |
| Length (L1) | mm | 3,800 |
| Length (L2) | mm | 1,610 |
| Flange length (L3) | mm | 592 |
| Width (W1) | mm | 1,060 |
| Width (W2) | mm | 424 |
| Height (H1) | mm | 1,600 |
| Infeed height excl. hopper (H2) | mm | 1,300 |
| Weight | kg | 1.500 |
| Electric power installed | kW | 15 |
| Drain connection | DN | 200 |
| Options: | | |
| Hopper | | |
| Control panel | | |

Head office:

Meyn Food Processing Technology B.V.
 Westeinde 6, 1511 MA Oostzaan (Amsterdam)
 P.O. Box 16, 1510 AA Oostzaan
 The Netherlands

T: +31 (0)20 2045 000
 F: +31 (0)20 2045 001
 I: www.meyn.com

MEYN

Poultry Processing Solutions

Meyn feather press

- Sturdy and reliable construction with limited number of moving parts.
- Proven high performance.
- Continuous operation, unaffected by irregularities in the input.
- Compact design, easily integrated in any situation.

