

# Meyn Quest

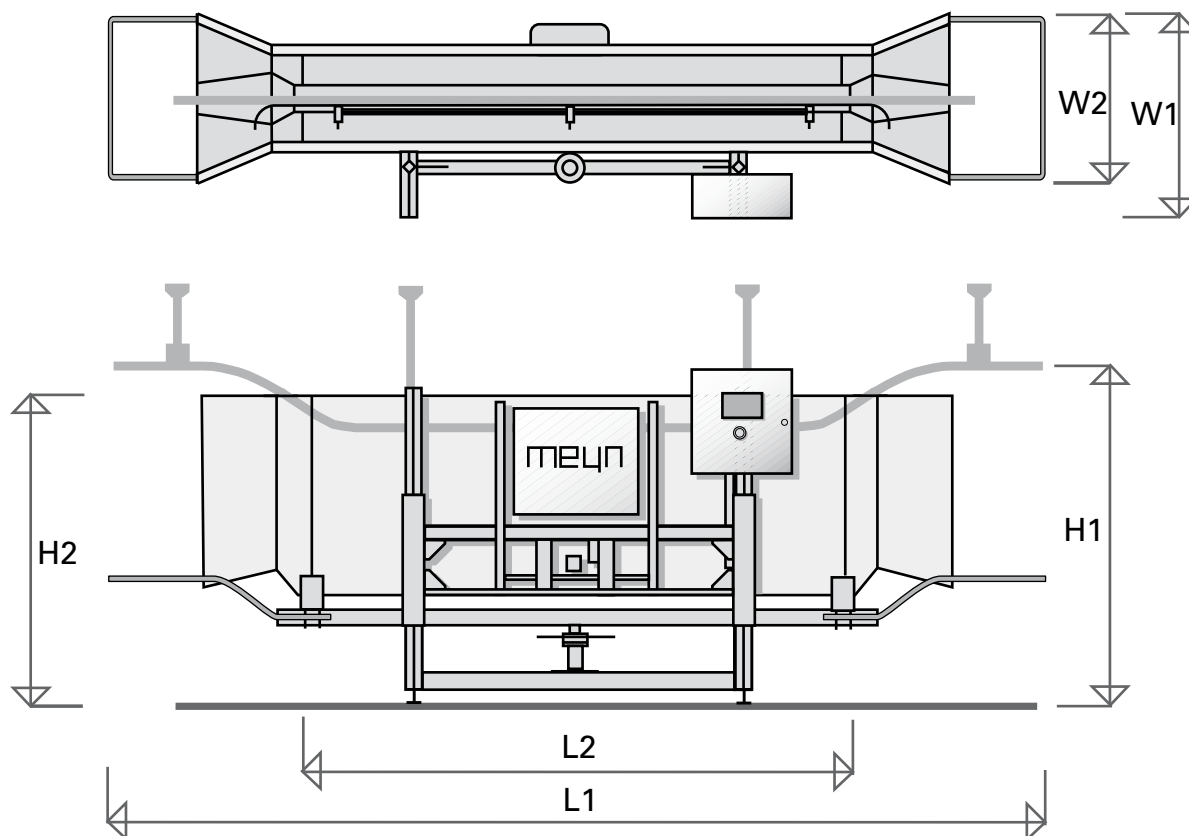

|                                      |         |       |       |        |        |
|--------------------------------------|---------|-------|-------|--------|--------|
| Capacity at 6" shackle pitch *       | BPH     | 6,500 | 8,500 | 10,400 | 12,400 |
| Capacity at 8" shackle pitch *       | BPH     | 4,900 | 6,300 | 7,800  | 9,300  |
| Capacity at 12" shackle pitch *      | BPH     | 3,200 | 4,200 | 5,200  | 6,200  |
| Live weight                          | kg      | 1-5   | 1-5   | 1-5    | 1-5    |
| Length (L1)                          | mm      | 5,750 | 6,500 | 7,250  | 8,000  |
| Effective water bath length (L2)     | mm      | 2,500 | 3,250 | 4,000  | 4,750  |
| Width (W1)                           | mm      | 1,300 | 1,300 | 1,300  | 1,300  |
| Width water bath (W2)                | mm      | 1,020 | 1,020 | 1,020  | 1,020  |
| Height (H1)                          | mm      | 2,000 | 2,000 | 2,000  | 2,000  |
| Height water bath (H2)               | mm      | 1,850 | 1,850 | 1,850  | 1,850  |
| Weight                               | kg      | 500   | 520   | 540    | 560    |
| Electric power installed             | kW      | 4.0   | 4.0   | 4.0    | 4.0    |
| Water connection                     | BSP     | 1/2"  | 1/2"  | 1/2"   | 1/2"   |
| Water consumption (heads immersed)   | l/bird  | 0.05  | 0.05  | 0.05   | 0.05   |
| Water consumption (breasts immersed) | l/bird  | 0.11  | 0.11  | 0.11   | 0.11   |
| Drain connection                     | Pipe/mm | Ø 50  | Ø 50  | Ø 50   | Ø 50   |

\* with a stunning time of at least 9 seconds per bird

## Head office:

Meyn Food Processing Technology B.V.  
 Westeinde 6, 1511 MA Oostzaan (Amsterdam)  
 P.O. Box 16, 1510 AA Oostzaan  
 The Netherlands

T: +31 (0)20 2045 000  
 F: +31 (0)20 2045 001  
 I: www.meyn.com

**MEYN**

Poultry Processing Solutions

# Meyn Quest

- Three different types of signals selectable.
- Very high percentage A-grade quality fillet.
- Hygienic design.
- Safety devices.

