

Meyn syncom rehanger

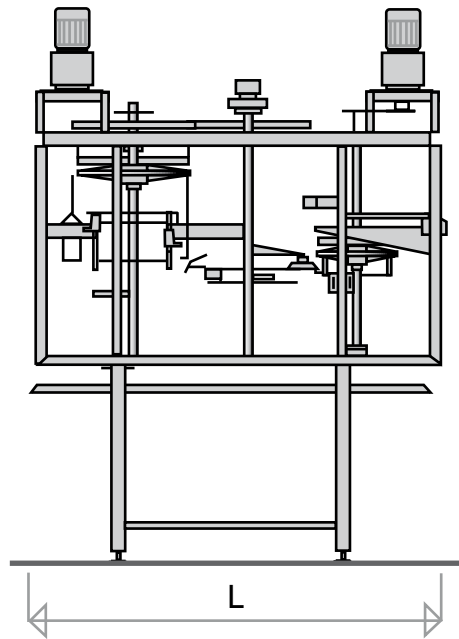
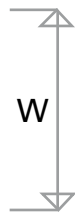
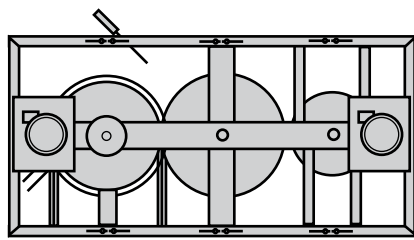

Model	Slaughtering - EV			EV - Chilling
	BPH	9,000	12,000	10,000
Capacity	BPH	9,000	12,000	10,000
Live weight	kg	0.5-5.5	0.5-4.0	0.5-4.0
Shackle pitch	inch	8" to 8"	6" to 6"	6" to 6"
Length (L)	mm	2,490	2,490	2,490
Width (W)	mm	1,250	1,250	1,250
Height (H1)	mm	2,390	2,390	2,390
Height (H2)	mm	850-1,250	850-1,250	850-1,250
Weight	kg	1,200	1,200	1,200
Compressed air connection	mm	6	6	6
Compressed air consumption	m ³ /h	incidental	incidental	incidental

Head office:

Meyn Food Processing Technology B.V.
 Westeinde 6, 1511 MA Oostzaan (Amsterdam)
 P.O. Box 16, 1510 AA Oostzaan
 The Netherlands

T: +31 (0)20 2045 000
F: +31 (0)20 2045 001
I: www.meyn.com

MEYN

Poultry Processing Solutions

Meyn syncom rehanger

- The highest rehangng performance in the business.
- A sturdy construction with a reliable operation.
- Extremely low maintenance cost.
- Suitable for a wide weight range at all speeds.

