

Meyn giblet chiller

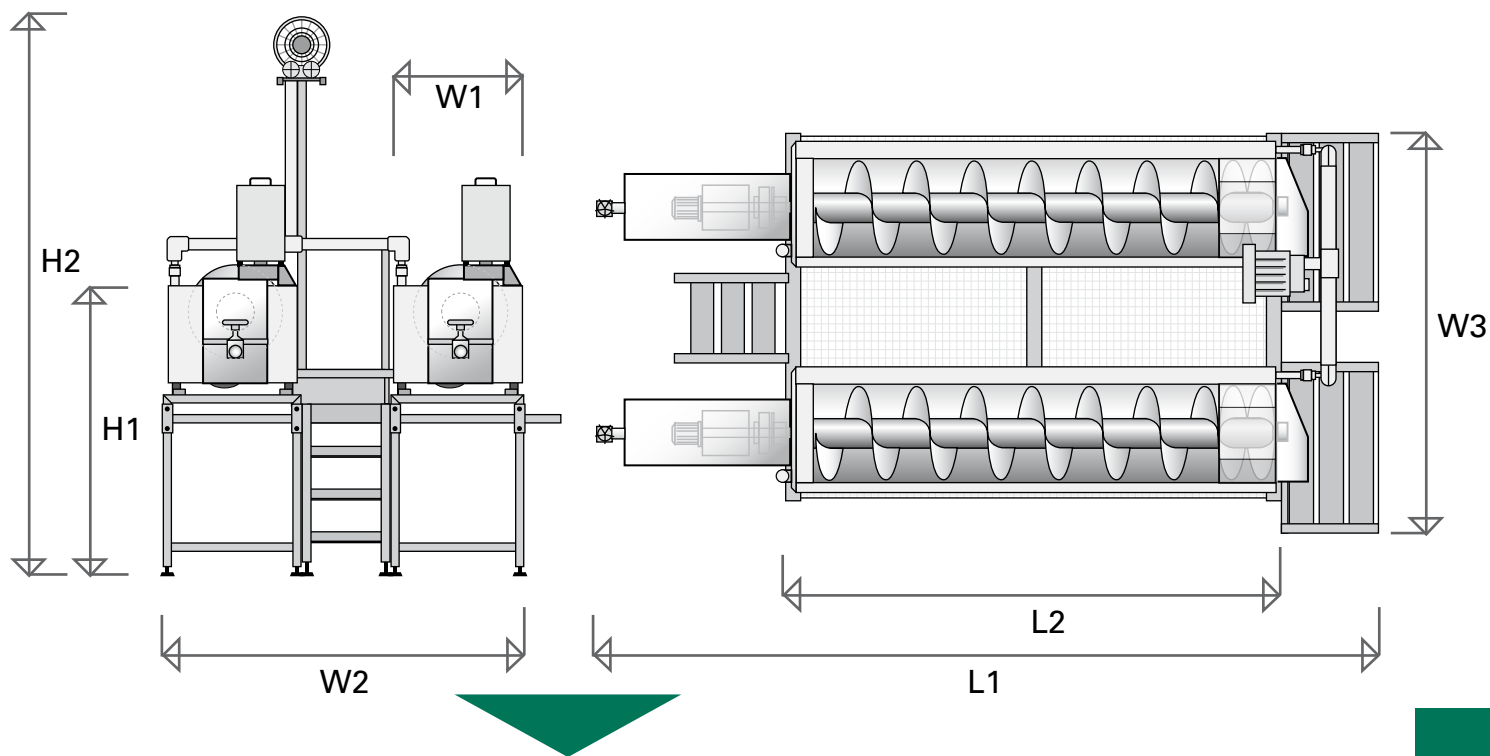

		<250	<500	<1,250
Capacity	kg/h	<250	<500	<1,250
Length (L1)	mm	3,650	4,650	4,650
Length (L2)	mm	2,500	3,500	3,500
Width (W1)	mm	650	650	910
Width (W2)	mm	1,880	1,880	2,420
Width (W3)	mm	2,070	2,070	2,530
Diameter drum	mm	500	500	810
Height (H1)* (floor-top of the chiller)	mm	615-1,595	665-1,595	950-1,830
Height (H2)* (floor-top of the blower)	mm	1,990-2,970	2,040-2,970	2,190-3,070
Weight	kg	600	700	800
Electric power installed (drive)	kW	0.12	0.12	0.12
Water connection	BSP	1"	1"	1"
Water consumption**	m ³ /h	0.63	1.25	3.15
Drain connection	BSP	2"	2"	2"
Options:				
Blower				
Electric power installed	kW	1.1	1.1	1.1
set of stands, platform, bow strainer				

* Height depending on the configuration

** Depending on the application

Head office:

Meyn Food Processing Technology B.V.
 Westeinde 6, 1511 MA Oostzaan (Amsterdam)
 P.O. Box 16, 1510 AA Oostzaan
 The Netherlands

T: +31 (0)20 2045 000
 F: +31 (0)20 2045 001
 I: www.meyn.com

MEYN

Poultry Processing Solutions

Technical Data Sheet

Meyn giblet chiller

- Effective chilling method.
- Sturdy construction.
- Easy to clean.

